



TELESCOPIC WHEEL LOADER | TM420

Gross power: 108kW (145hp) | Lift capacity: 4100kg | Lift height: 5450mm



SMART TECHNOLOGY FROM JCB.

JCB'S SMART HYDRAULICS PACKAGE IMPROVES CYCLE TIMES WHILST DELIVERING A REDUCTION IN THE AMOUNT OF FUEL CONSUMED.

Introducing JCB Smart Hydraulics.

JCB's Euro Stage IV/Tier 4 Final TM420 is enhanced by JCB's new Smart Hydraulics package. High flow auxiliaries and a seat-mounted servo joystick brings improved comfort and productivity. These features are in addition to JCB's unique regenerative hydraulics system which improve cycle times whilst reducing the amount of fuel used to move the same amount of material.

Also part of the Smart Hydraulics package are end-of-stroke damping on boom lift, extension/retract and attachment dump cylinder, whilst the Auto SRS further improves comfort and productivity.



Regenerative hydraulics.

1 Making the most out of every drop of precious fuel, gravitational forces are harnessed to make boom lowering and retract more energy efficient and productive.

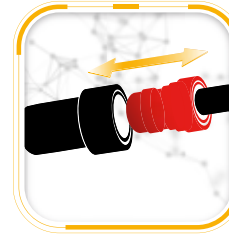

Hydraulic auxiliary venting.

2 The cab boasts a pressure release button for front and rear hydraulic services ensuring quick and safe changeover of attachments.



Boom end damping.

3 Improved material retention and smoother cycle work with boom end damping on lift, extend, retract and bucket dump cycles.



Optional Auto SmoothRide System.

4 Auto SRS engages at speeds of over 2.5mph (4kph). This improves load retention when travelling at speed on roads and fields.



High flow hydraulics.

5 High flow pipework gives greater flow to the boom, ideally suited to attachments demanding high flow such as silage defacers and straw spreaders.



THE POWER TO PERFORM.

THE CLASS LEADER WHEN IT COMES TO LIFT CAPACITY AND TEAROUT FORCE, COMBINED WITH 5.45M LIFT HEIGHT, 3.05M FORWARD REACH AND THE SUPERB JCB ECOMAX ENGINE. THERE'S NOTHING THE TM420 CAN'T HANDLE.

Redefined productivity.

1 Auto SmoothRide System (SRS) engages at speeds of 2.5mph (4kph). This improves load retention and comfort (and, in turn, productivity) when travelling at speed on roads and fields. The system can be manually engaged with the boom in any position.

2 TM420 features our JCB EcoMAX Tier 4 Final engine with variable geometry turbo, giving increased performance at low engine speed for improved cycle times and tractive effort. This 4.8 litre 145hp (108kW) engine delivers a massive 560Nm of torque at low engine speeds for optimum response.

3 By producing high levels of power and torque even at engine speeds as low as 1300-1400rpm, EcoMAX can provide fuel-efficient matching of transmission and hydraulics.

4 Our optional hydraulic rear tow hitch further increases machine versatility whilst its fold-up design prevents impact damage and grounding when working on gradients or uneven ground.

2



1



3



4

Traction and travel.

- 5** The JCB TM420 gives you ultimate traction and performance in soft, muddy ground, thanks to an oscillating front and rear chassis and optional limited slip differentials and 4WD as standard.
- 6** Lock-up in the torque converter is selectable in gears four to six on the TM420 for enhanced efficiency and productivity.
- 7** The TM420's variable flow auxiliary hydraulics are easy to use, designed to maximise productivity and efficiency. This flow sharing system with a variable flow piston pump also allows for multiple functions to be performed at the same time, reducing cycle times.
- 8** Constant flow hydraulics are intuitive to use, with an in cab display of flow rate, which can be adjusted on the go, making it perfect for straw spreader or sweeper use. Large 5/8 auxiliary pipework is fitted as standard allowing greater flow rate down to the attachment.



5



6

Torque converter locking on the transmission gives 100% efficiency for improved fuel economy.



8



8



STRENGTH YOU CAN RELY ON.

THE TM420 HAS BEEN DESIGNED AND BUILT FROM SCRATCH TO DELIVER THE STRENGTH AND POWER YOU'RE LOOKING FOR IN AN ARTICULATED MACHINE. NO COMPROMISE.

Proven reliability.

1 The TM420's stringent testing program has included high stress loading of the chassis, boom and other key components, as well as repeated transmission use over thousands of typical agricultural work cycles.

2 The centrally mounted lift, tilt and extension rams eliminate boom twisting and are held in place by centrally-mounted keyhole castings for even greater structural integrity.

3 At JCB, we make our own hydraulic cylinders, cabs, axles, transmissions and engines – all designed to work in perfect harmony for optimum reliability.

4 To provide long-term protection, we dip every TM420 cab and various bodywork panels in electrophoretic alloy before painting it.



Our unique oscillating centre pivot point makes the most of traction by maintaining even weight distribution over each of the four wheels. It also gives extra stability and ride comfort.



Designed to work hard.

- 5 The TM420 features heavy duty chassis and boom construction for ultimate strength and reliability.
- 6 A heavy-duty centre joint takes both vertical and horizontal loadings for maximum durability and rigidity.
- 7 Wide-core cooling pack with optional hydraulic reversing fan removes built up debris. Reverse fan can be set to manual or automatic at a flick of a switch.
- 8 The JCB TM420's cast rear counterweight helps prevent impact damage.
- 9 Recessed rear lights mounted above the counterweight are well protected.
- 10 The hydraulic hoses are routed within the main boom structure to guard against damage.



IN CONTROL, IN COMFORT.

THE TM420 MAKES LIFE EASIER. FIRST OF ALL, IT'S EASY TO OPERATE THANKS TO ERGONOMIC, INTUITIVE CONTROLS AND INTELLIGENT FEATURES. SECONDLY, THEY PROVIDE A COMFORTABLE ENVIRONMENT TO WORK IN, MAKING OPERATORS MORE PRODUCTIVE.

At your command.

1 From the high, centrally mounted driving position you're in complete control, with a low boom pivot and large glass areas giving an unhampered 360 degree view.

2 For ergonomic, fast and precise control, the TM420 is fitted with a fully proportional single lever seat mounted servo joystick controls.

Joystick-mounted manual gear changes means you can shift gears, speed and direction quickly and easily with one ergonomic control. The TM420 also benefits from automatic gear changes.

3 Our new HVAC system keeps operators comfortable and focused for longer, the 3-speed fan heater can help create the right working temperature all year round, from the depths of winter to hot harvesting days. Optional air conditioning makes it even easier to find the perfect cab temperature.

4 A selectable transmission dump on the foot brake provides superb multi-functioning and increased engine speeds during loading or rehandling.

5 An additional benefit of the TM's articulated steering is the built-in sideshift which makes it easier to position attachments and place loads accurately.

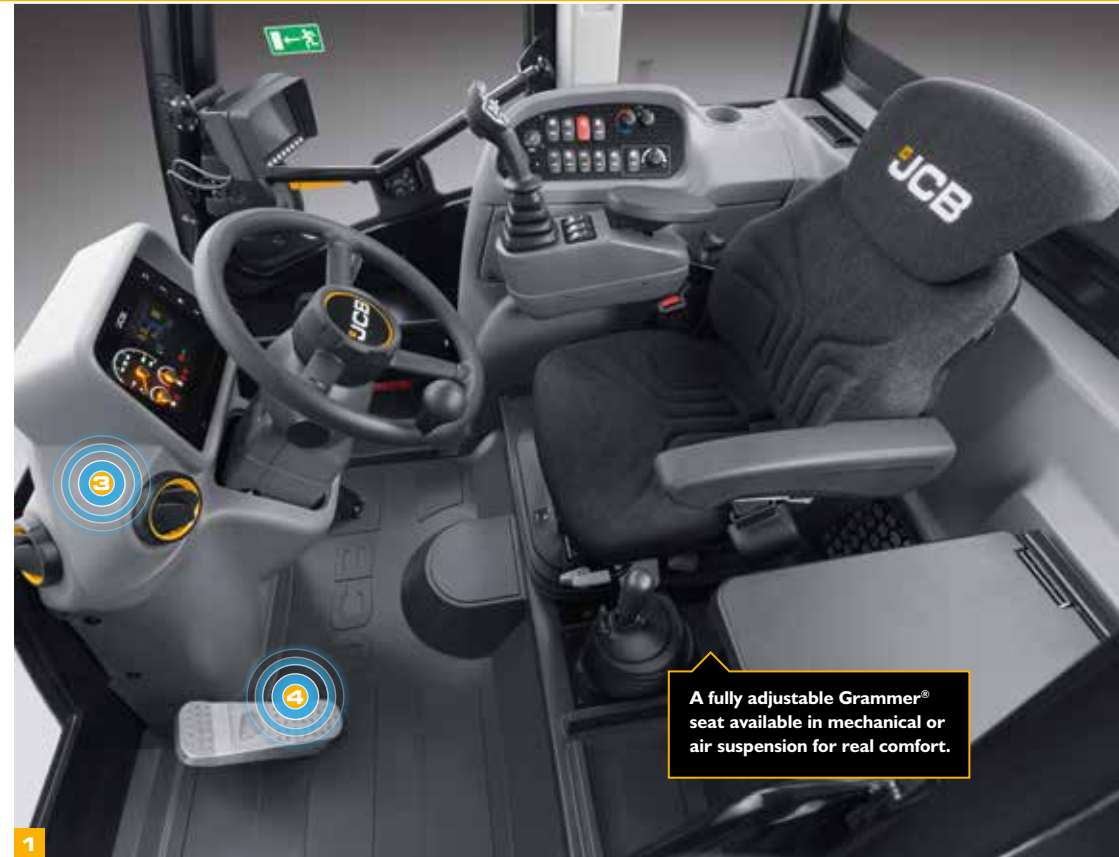

A fully adjustable Grammer® seat available in mechanical or air suspension for real comfort.



Sitting comfortably.

5 Boom end damping on boom raise, extend, retract and dump reduces shock to the operator and the machine itself.

6 The TM420 cab is large and roomy with plenty of storage for home comforts and work essentials.

7 TM420's are fitted with an auxiliary service as standard, ensuring they can be used with a wide range of attachments, ensuring maximum versatility. The cab boasts a pressure release button for the front and rear hydraulic auxiliary services too. A constant flow auxiliary fitted as standard with twin auxiliary optional.

8 An LED colour screen on the dash provides operators with useful information such as efficient running, fuel remaining, fuel used since last fill, and current average fuel consumption figures, with Tier 4 Final/Stage IV this also shows Diesel Exhaust Fluid (DEF) level and any additional information.

9 Backlit switches ensure quick and accurate control recognition, even in the dark.

10 Adaptive load control technology automatically controls hydraulic operation, helping to maintain longitudinal stability of the machine.



360 degree cab mounted and boom LED worklight options optimise visibility at night or in other darkened operating areas such as outbuildings, making 3am look like 3pm. There is also a useful optional LED hitch light available to allow trailer couplings in limited visibility.



A SMART INVESTMENT.

WHEN YOU OWN A JCB, YOU OWN A MACHINE THAT'S RENOWNED FOR HAVING HIGH RESIDUAL VALUES AROUND THE WORLD. COMBINED WITH EFFICIENT DESIGN THAT SAVES YOU MONEY, IT'S A REAL BUSINESS ASSET.

EcoMAX saves you money.

1 JCB's new efficient EcoMAX Tier 4 Final/Stage IV engine produces its power and torque at low engine speeds for great responsiveness.

2 The 145hp (108kW) JCB EcoMAX engine is fitted with a variable speed cooling fan that automatically reacts to ambient temperatures, adjusting fan speed to maximise fuel efficiency and reduce in cab noise levels.

3 High back-off power brakes reduce viscous drag during roading and rehandling, which improves fuel economy.

4 TM420's load-sensing hydraulics only consume power on demand, conserving fuel.



EcoMAX saves you money (cont.)

5 Innovative all-new smart regenerative hydraulics helps to make the most of every drop of precious fuel. Gravitational forces are harnessed to make boom lowering and retraction more energy efficient than ever, allowing the boom to retract and lower in less than five seconds!

6 JCB's innovative Clean Burn technology helps our engines to meet Tier 4 Final/Stage IV regulations without exhaust after-treatments like DPFs. This means, of course, that costly DPF regeneration or costly replacement is never a worry. Instead, the TM420 uses a sealed-for life Selective Catalytic Reduction (SCR) system. Among the numerous benefits of this setup is the fact that there's no loss of productivity due to DPF regeneration.

7 The TM420 is fitted with TorqueLock in gears four to six for greater speed, quicker journey times between farm and field, and reduced fuel consumption when roading.



5



6



7

SERVICING MADE EASY.

THE TM420 IS LOW MAINTENANCE AND EASY TO SERVICE, WHICH MEANS LESS DOWNTIME, AND MORE WORKING AND EARNING TIME. THEY'RE ALSO DESIGNED FOR CONSUMMATE SAFETY, PROTECTING BOTH YOU AND YOUR INVESTMENT.

Maintenance made easy.

Next generation In-Cab display incorporating In-Cab daily checks including coolant level and engine oil level.

500 hour greasing intervals maximise machine uptime courtesy of our graphite impregnated bronze bushes.

1 It's easy to fill both the diesel and DEF tanks from ground level. Both tanks also have built-in pre-filters in the filler necks to guard against dirt and contaminants as well as separate keys to prevent cross contamination. Housed inside the DEF tank are DEF quality sensors.

2 TM420's self-lubricating boom wear pads and dry boom lubrication provides virtually maintenance free operation.

3 Engine oil, hydraulic oil and fuel filters are centrally located for easy servicing. The air filter is easily accessed too, and its double-element design simplifies cleaning.

4 The TM420 is equipped with a large, wide service bay that's accessed via a gas-assisted bonnet. This setup allows fast and easy inspection around three sides of the engine.



3



1



1



2



4

Keeping you safe.

- 7** Excellent cab access, with three points of contact and ergonomically positioned grab handles and foot step.
- 8** Hose burst check valves on the rams prevent collapse if a hose fails.
- 9** The low boom profile and low boom pivot make for superb forward visibility.
- 10** Adaptive Load Control technology automatically controls hydraulic operation, helping to maintain the longitudinal stability of the machine.
- 11** In order to protect your investment, the TM420 is available with JCB LiveLink telematics tracking realtime vehicle position as standard with optional immobiliser key.
- 12** Optional rear-view camera displays an unobstructed rearward view on the in-cab colour monitor onboard your TM420.
- 13** Our in-cab electric two stage quickhitch isolation protects against accidental release of attachments.



11



11



12



13

LIVELINK, WORK SMARTER.

JCB LIVELINK IS AN INNOVATIVE SOFTWARE SYSTEM THAT LETS YOU MONITOR AND MANAGE YOUR MACHINES REMOTELY – ONLINE, BY EMAIL OR BY MOBILE PHONE.

Productivity and cost benefits –

Machine location information can improve fleet efficiency and you may even enjoy reduced insurance costs courtesy of the added security that LiveLink brings.

** Note: Please consult your local dealer for Livelink availability*



Maintenance benefits – Accurate hours monitoring, maintenance history records, critical machine alerts and service alerts improve maintenance planning.

Security benefits – Real-time geofencing lets you set operating zones and curfew alerts that tell you when your machinery outside of pre-determined times. Location information helps you store machines safely.

VALUE ADDED.

JCB'S WORLDWIDE CUSTOMER SUPPORT IS FIRST CLASS. WHATEVER YOU NEED AND WHEREVER YOU ARE, WE'LL BE AVAILABLE QUICKLY AND EFFICIENTLY TO HELP MAKE SURE YOUR MACHINERY IS PERFORMING TO ITS FULL POTENTIAL.



1 Our Technical Support Service provides instant access to factory expertise, day or night, while our Finance and Insurance teams are always on hand to provide fast, flexible, competitive quotes.

JCB Assetcare offers comprehensive extended warranties and service agreements, as well as service-only or repair and maintenance contracts. Irrespective of what you opt for, our Maintenance teams around the world charge competitive labour rates, and offer non-obligation quotations as well as fast, efficient insurance repair work.



2 The global network of JCB Parts Centres is another model of efficiency; with 16 regional bases, we can deliver around 95% of all parts anywhere in the world within 24 hours. Our genuine JCB parts are designed to work in perfect harmony with your machine for optimum performance and productivity.

Note: JCB LIVELINK and JCB ASSETCARE may not be available in your region, so please check with your local dealer.

STATIC DIMENSIONS

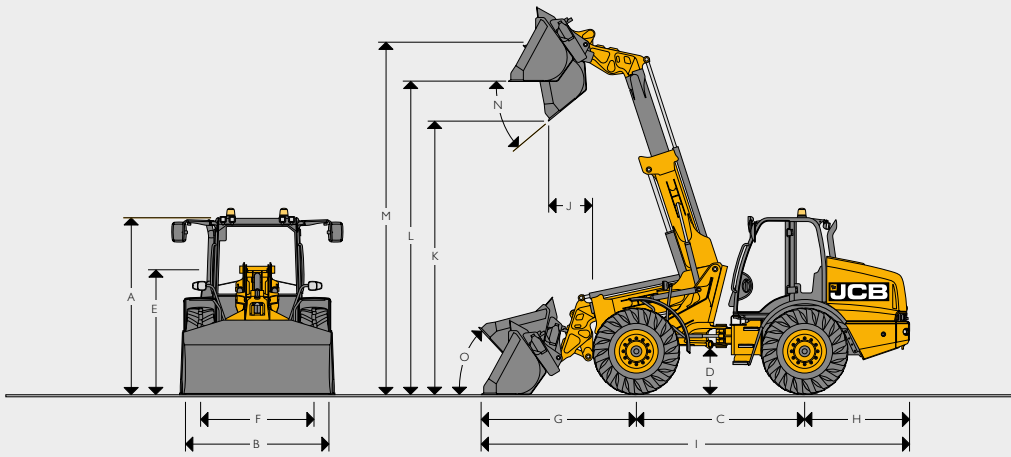

STATIC DIMENSIONS

A	Overall height	mm	2827
B	Overall width (over tyres)	mm	2350
C	Wheelbase	mm	2758
D	Ground clearance to bottom of axle	mm	466
E	Height to top of boom pivot	mm	1975
F	Wheel track	mm	1860
G	Axle to shovel toe plate	mm	2532
H	Axle to counterweight face	mm	1721
I	Total length*	mm	7011
J	Dump reach	mm	735
K	Dump height	mm	4411
L	Load over height	mm	5064
M	Pin height	mm	5661
N	Maximum dump angle	degrees	39
O	Roll back at carry	degrees	43
	Total length to front of hitch	mm	5829
	Inside radius	mm	3880
	Outside radius (edge of tyre)	mm	5060
	Outside radius (over shovel)	mm	5680
	Articulation angle	deg	± 40°
	Operating weight	kg	9530
	Front axle weight	kg	3280
	Rear axle weight	kg	6250
	Tyres used for specifications	Michelin XMCL 480/80R26	
	Bucket used for specifications	1.6m ³ GP	
	Hitch used for specification	Q-Fit	

*Please note total length: machine fitted with standard bucket - in carry position, shovel crowded fully back.

ENGINE

Manufacturer	JCB	
Model	EcoMAX	
Capacity	litres	4.8
Aspiration	Turbocharged/charge cooled	
Number of cylinders	4	
Power rating		
Gross power to SAE J1995/ISO 14396	kW (hp)	108 (145) @ 2200 rpm
Net power to J1349/EEC 80/12	kW (hp)	101 (135) @ 2200 rpm
Torque rating		
Gross torque	Nm	560 @ 1500 rpm

TRANSMISSION

Type	Powershift	
Make	JCB	
Model	PS760 - 6 Speed	
Max. travel speed	kph	40

AXLES

Type	Epicyclic hub reduction	
Make	JCB	
Model	PD87 Max-Trac	
Overall axle ratio/ drop box ratio	15.23	
Chassis angle oscillation	degrees	± 10°

BRAKES

Service brakes	In board oil immersed brakes	
Parking brake	Cable operated disc brake on transmissions output shaft	

NOISE AND VIBRATION

			Uncertainty	Measurement conditions
Noise at the operator station	LpA	73 dB	+/- 1 dB	Determined in accordance with the test method defined in ISO 6396 and the dynamic test condition defined on 2000/14/EC.
Noise emission from the machine	LWA	107 dB	+/- 1 dB	Guaranteed equivalent sound power (external noise) determined in accordance with the dynamic test conditions defined in 2000/14/EC.
Whole body vibration	m/s ²	0.39	+/- 0.11 dB	ISO 2631-1:1997 normalised to an 8h reference period and based upon a test cycle comprising of loader work (soil).
Hand-arm vibration	m/s ²	<2.5	N/A	ISO 5349-2:2001 dynamic test conditions.

SERVICE FILL CAPACITIES

Hydraulic tank	litres	97
Fuel tank	litres	160
Engine oil sump	litres	14
Axle oil (front) including hubs	litres	25
Axle oil (rear) including hubs	litres	25
Drop box	litres	1.3
DEF	litres	29
Transmission	litres	19

HYDRAULICS

Pump type	Variable displacement piston pump	
Pump maximum flow	l/min	160
Pump maximum pressure	bar	260

Hydraulic cycle times

Boom raise	seconds	5.1
Boom lower	seconds	4.7
Extend	seconds	3.6
Retract	seconds	3.5
Bucket dump	seconds	2.9
Bucket crowd	seconds	3.4
Total cycle time	seconds	15

ELECTRICAL SYSTEM

System voltage	Volt	12
Alternator output	Amp Hour	150
Battery capacity	Amp Hour	120

TYRE OPTIONS

Manufacturer	Size	Type	Application	Dimensional changes	
				Overall height (mm)	Width over tyres (mm)
Michelin	480/80R26	XMCL	AG	-	-
Michelin	480/80R26	BIBLOAD	AG/EM	+8	0
Michelin	620/70R26	CEREXBIB	AG	+7	+201
Michelin	17.5R25	XHA	EM	-54	-19
Michelin	17.5R25	XSNOPUS	EM	-60	-19
Nokian	17.5R25	LOADER GRIP TL	EM	-42	-20
JCB	17.5R25	EARTHMOVER	EM	-23	-22

LOADER PERFORMANCE - FORK FRAME WITH FORKS

Maximum lift capacity to full height with forks	kg	4100
Lift capacity at full reach	kg	2250
Lift height	mm	5450
Maximum forward reach	mm	3050
Straight tipping load - forks with 500mm load centre*	kg	6670
Full turn tipping load - forks with 500mm load centre*	kg	5200 **
Full turn tipping load - forks calculated @ 80% load factor*	kg	4160 **
Full turn tipping load - forks calculated @ 60% load factor*	kg	3120 **
Breakout force - tearout	kg	7200

** Straight and Full Turn Tipping Load with forks and direct mount to Q-Fit carriage to EN474 (ISO 14397)

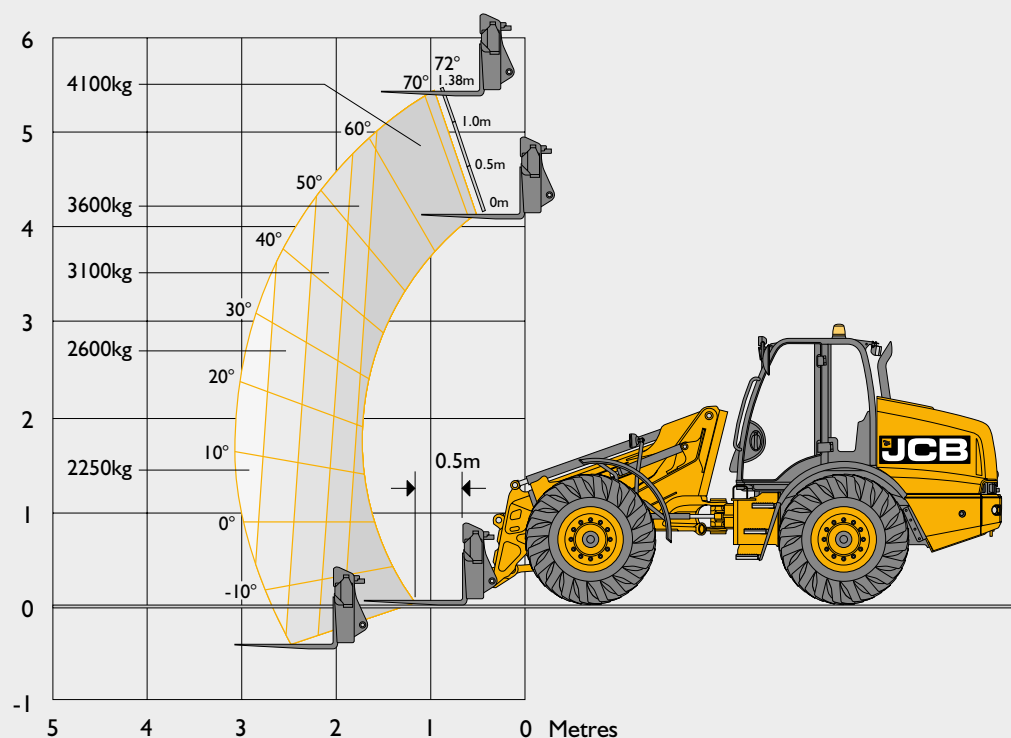

STANDARD/OPTIONAL EQUIPMENT			
ENGINE AND COOLING		CAB	
145hp JCB EcoMAX engine	•	ROPS/FOPS safety structure	•
Cyclonic air filter	•	Laminated screen	•
Air intake scavenge system	•	Fully adjustable mechanical seat	•
Widecore cooling pack	•	Air suspension seat	+
Auto reversing fan	+	Interior light	•
		LED interior light	+
		Tilt and telescopic steering column	•
TRANSMISSION / AXLES		Adjustable joystick control console and armrest	•
6 speed Powershift transmission	•	Front and rear wash / wipe	•
Lock-up torque converter in gears 4 - 6	•	3 speed heater fan	•
40kph travel speed	•	Air conditioning	+
Transmissions disconnect on footbrake	•	RH opening window with lock back	•
Forward / reverse controls on joystick	•	LH opening door with door lock back	•
Column mounted transmission selector	•	LH Sliding window	+
In board oil immersed disc brakes	•	Single lever joystick controls	•
Limited slip differentials front and rear	+	Loader control isolator	•
		External rear view mirrors	•
HYDRAULICS		Front and roof screen blinds	•
Servo controls	•	Fire extinguisher	+
Flow sharing hydraulics	•	Additional storage box	+
Proportional boom and auxiliary controls	•	Tool box	+
Adjustable constant flow hydraulics	•		
Variable displacement piston pump	•	ELECTRICAL	
Priority steer valve	•	Road lights front and rear	•
Hose burst check valves	•	LED road lights front and rear	+
JCB Adaptive Load Control	•	Reverse lights	•
JCB Smoothride system	+	Battery isolator	•
Biodegradable hydraulic oil	+	Rotating beacon	+
		Twin beacons	+
		Four front and four rear worklights	+
		LED boom worklights	+
		Halogen twin reverse light kit	+
		Reverse foglight kit	+
		LiveLink telematics	•
		LED 360 degree worklights	+
		LED Four front and four rear worklights	+
		LED tow hitch light	+
		12v in-cab power socket	•
		Reverse camera with colour screen	+
		CHASSIS AND BODYWORK	
		Plastic front and rear fenders	•
		Fixed bottom step	•
		Full width rear counterweight	•
		Recovery hitch	•
		Prop shaft guard	•
		Grease gun and cartridge	+
		Deluxe exterior mirrors	•
		Hydraulic tow hitch	+
		Rockinger hitch (15000kg)	+
		Trailer electrics	+
		Trailer braking	+
		Rear auxiliary	+
		Rear belly guards	+
		Mid belly guards	+
		LOADER	
		Parallel lift	•
		End damping on boom lift, extend, retract and bucket dump	•
		Pin and Cone carriage (CAT III)	+
		JCB Q-fit carriage	+
		Industrial carriage	+
		Electrical in cab quickhitch pin isolation	•
		5/8" Auxiliary couplers	+
		ATTACHMENTS	
		Grain shovel 4.0m ³	+
		Grain shovel 2.7m ³	+
		Muck grab 2.4m ³	+
		GP shovel 1.6m ³	+
		Pallet forks 1067mm	+
		Pallet forks 1200mm	+
		STANDARD	•
		OPTIONAL	+
		NOT AVAILABLE	×

NB. Regional variations may apply to standard and optional equipment







ONE COMPANY, OVER 300 MACHINES.

Your nearest JCB dealer

Telescopic Wheel Loader TM420

Gross power: 108kW (145hp) Lift capacity: 4100kg Lift height: 5450mm

JCB Agriculture, Rocester, Staffordshire ST14 5JP.

Tel: +44 (0)1889 590312 Email: salesinfo@jcb.com

Download the very latest information on this product range at: www.jcb.com

[f facebook.com/JCBAg](https://www.facebook.com/JCBAg)
[t @JCBAgriculture](https://twitter.com/JCBAgriculture)
[y youtube.com/JCBAgriculture](https://www.youtube.com/JCBAgriculture)

©2014 JCB Sales. All rights reserved. No part of this publication may be reproduced, stored in a retrieval system, or transmitted in any form or by any other means, electronic, mechanical, photocopying or otherwise, without prior permission from JCB Sales. All references in this publication to operating weights, sizes, capacities and other performance measurements are provided for guidance only and may vary dependant upon the exact specification of machine. They should not therefore be relied upon in relation to suitability for a particular application. Guidance and advice should always be sought from your JCB Dealer. JCB reserves the right to change specifications without notice. Illustrations and specifications shown may include optional equipment and accessories. All images are correct at time of print. The JCB logo is a registered trademark of J C Bamford Excavators Ltd.

9999/6023 en-GB 03/18 Issue 1

